

Challenger Chain Block

Challenger Chain Blocks feature better quality in a new compact design. Suitable for many applications in the mining, construction, industrial and automotive industry.

- Gear system design for reduced effort when lifting loads
- Key internal components are CNC machined before being heat treated toughened
- All Challenger models are manufactured to comply with AS1418.2.

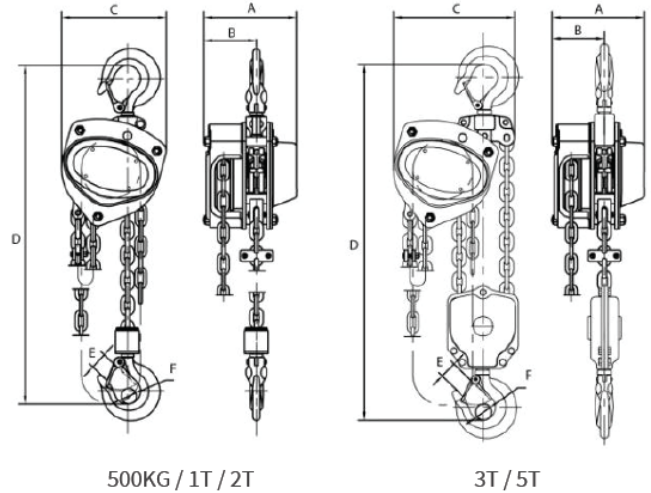

Part No.	WLL (tonnes)	HOL (mtr)	A (mm)	B (mm)	C (mm)	D (mm)	E (mm)	F Dia. (mm)	Weight (kg)
215102	0.5	3	128	75	130	280	22	20	9
215202	0.5	6	128	75	130	280	22	20	10
215103	1	3	142	76	150	330	26	25	12
215203	1	6	142	76	150	330	26	25	16
215104	2	3	175	88	185	385	35	33	20
215204	2	6	175	88	185	385	35	33	25
215105	3	3	158	80	220	510	37	36	23
215205	3	6	158	80	220	510	37	36	34
215106	5	3	183	90	225	615	43	43	39
215206	5	6	183	90	225	615	43	43	50

HEAD OFFICE

A. 4 Christensen Rd, Yatala Q 4207

T. 07 3801 6565

W. stenhouselifting.com.au

E. sales@stenhouselifting.com.au

YATALA 07 3801 6565

MARYBOROUGH 07 4122 1193

WACOL 07 3728 4545

